

THE **WIND SPEED ANEMOMETER** IS A ROTATING CUP, REED SWITCH SENSING DEVICE THAT WORKS WITH SAPPHIRE FOUNTAINS SPLASH WIZARD INDUSTRIAL FOUNTAIN CONTROL SYSTEMS FOR WIND CONTROL. THE PULSE SIGNAL FROM THIS ANEMOMETER IS USED FOR CONTROLLING PUMP SPEEDS & SHUT-OFF DURING LOW, MEDIUM, AND HIGH WIND EVENTS.

SPECIFICATIONS

- DIMENSIONS - SEE BELOW (FOR GENERAL FIT PURPOSES ONLY)
- VOLTAGE: 3-24 VDC (OPTIMAL LIFE SPAN IN LOWER VOLTAGE RANGE)
- WIRE: 25 FT LENGTH, 2 CONDUCTOR 20 AWG
- WIND SPEED RANGE: 5-125 MPH
- MOUNTING OPTIONS:
 - SCREW HOLES IN VERTICAL BRACKET
 - INSERT VERTICAL MOUNT BRACKET INTO CONDUIT FITTING WITH 1/2" SE WATER TIGHT CONDUIT CONNECTOR
 - REMOVE ATTACHMENT SCREW & VERTICAL MOUNT BRACKET, GLUE ANEMOMETER BODY INTO 1" PVC SOCKET FITTING

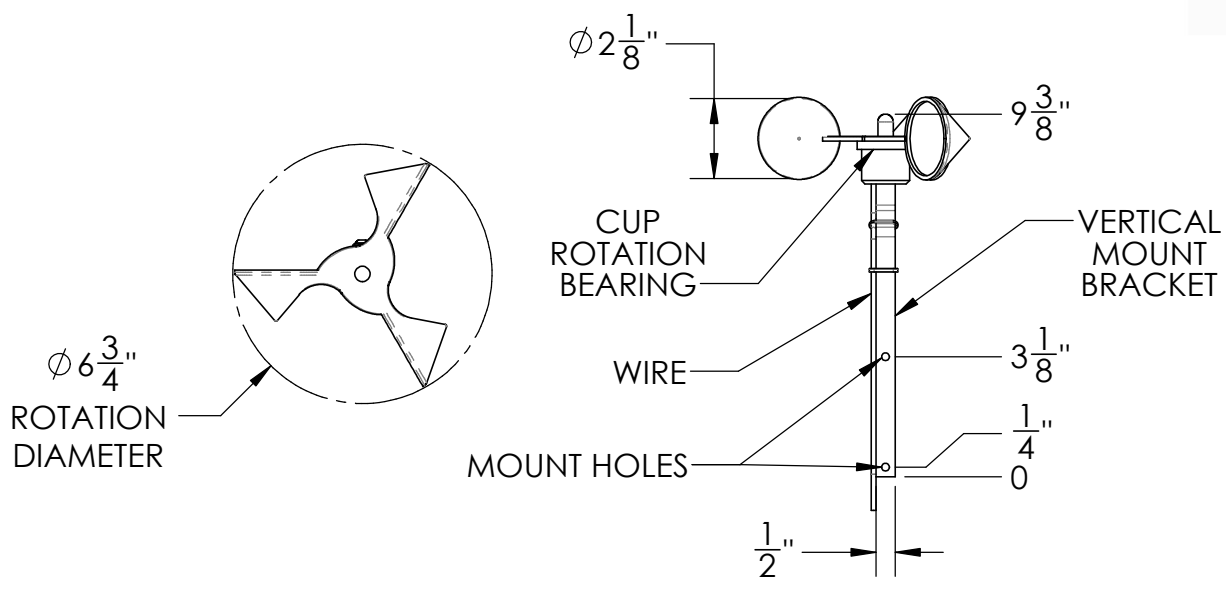
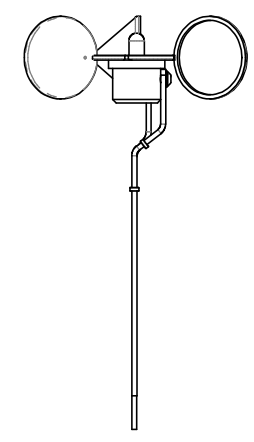

801-837-2199
sapphirefountains.com

DESCRIPTION
ANEMOMETER, PADDLE, 3-24 VDC

PROPRIETARY & CONFIDENTIAL

THE INFORMATION CONTAINED IN THIS DRAWING IS THE SOLE PROPERTY OF SAPPHIRE FOUNTAINS LLC. ANY REPRODUCTION IN PART OR AS A WHOLE WITHOUT WRITTEN PERMISSION OF SAPPHIRE FOUNTAINS IS PROHIBITED.

PART NUMBER
PDT-0016

REV A

DIMENSIONS ARE IN INCHES

SHEET 1 OF 1